

**HA** series Horizontal Deflection Current Correction Use

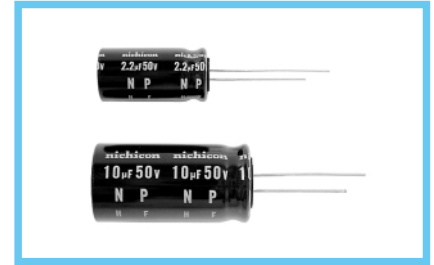

- Designed specifically for horizontal deflection current correction of TV's where high frequencies and high ripple currents are applied.
- Adapted to the RoHS directive (2002/95/EC).



## Specifications

Item	Performance Characteristics	
Category Temperature Range	-25 ~ +85°C	
Rated Voltage Range	25 · 50V	
Rated Capacitance Range	2.2 ~ 10µF	
Capacitance Tolerance	±10% at 120Hz, 20°C	
Leakage Current	After 5 minutes' application of rated voltage, leakage current is 100 (µA) or less.	
tan δ	Measurement frequency : 120Hz, Temperature : 20°C	
	Rated voltage (V)	25, 50
	tan δ (MAX.)	0.05
Endurance	After 1000 hours' application of DC 12V on which the specified allowable ripple current is superimposed at 70°C, capacitors meet the characteristic requirements listed at right.	
	Capacitance change	Within ±15% of initial value
	tan δ	200% or less of initial specified value
Shelf Life	After storing the capacitors under no load at 85°C for 500 hours, and after performing voltage treatment based on JIS C 5101-4 clause 4.1 at 20°C, they will meet the specified value for endurance characteristics listed above.	
	Leakage Current	Initial specified value or less
Marking	Printed with white color letter on black sleeve.	

## Radial Lead Type

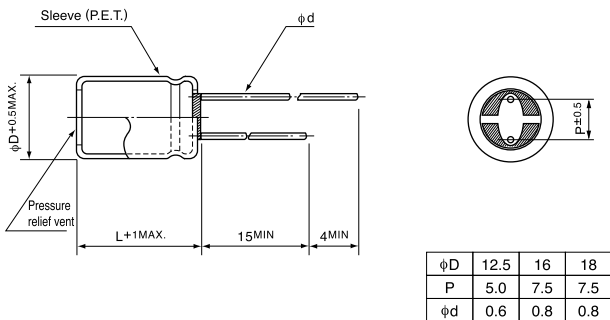

## Type numbering system (Example : 25V 3.3µF)

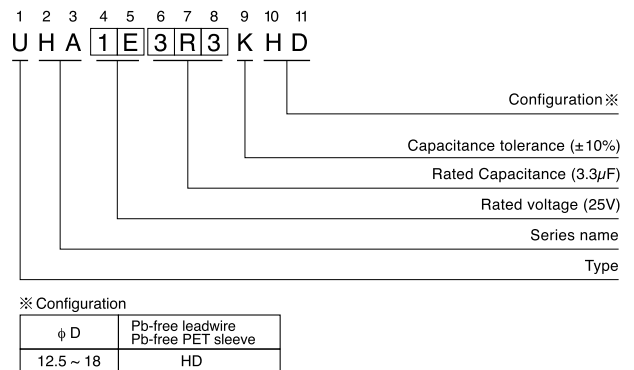

## Dimensions

Cap. (µF)	Code Item	25 (1E), 50 (1H)	
		Case size	Rated ripple
2.2	2R2	12.5 × 25	5
3.3	3R3	16 × 25	6
4.7	4R7	16 × 31.5	7
5.6	5R6	16 × 31.5	7.5
6.8	6R8	16 × 35.5	8
10	100	18 × 35.5	10

Case size (mm)

Rated ripple  
Ripple (Ap-p) at 70°C 15.75kHz

Please refer to page 19, 20, 21 about the formed or taped product spec.  
Please refer to page 3 for the minimum order quantity.